



Class 2 65W Constant Current Dimmable LED Driver

XLA65

Forward/Reverse Phase Dimmable LED Driver

The XLA65 is a TRIAC/ELV dimmable LED driver which offers maximum dimming performance and the widest dimming compatibility in the market today. Incorporating proprietary smart-dim technology, the XLA65 provides flicker-free, 0-100% dimming and has been tested to work with over 60 brand name dimmers on the market. Rated IP 66, XLA 65 comes in unique long-slim form factor, making it suitable for a wide variety of LED illumination applications.

Features

- Best-in-class TRIAC/ELV dimmable LED power supply
- 0-100% flicker-free dimming
- Unique Long- Slim form factor for width constrained space applications
- Compatible with over 60 brand name TRIAC/ELV dimmers on the market
- IP 65 Rated
- UL/cUL CE, FCC approved
- Up to 3 Years Warranty

Applications

- Down-lights
- Light Panels
- Office General Illumination
- Retrofit Lighting
- Residential Lighting
- Signage
- Spotlights
- Tube lighting (driver-less)



Model Selection Key

XLA(A) 65-BCV-D

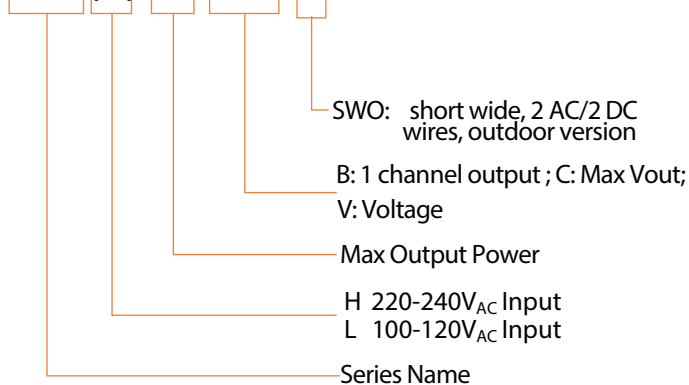

Model Number		Channel(s) Output	CC Output				Max Output Power (Per Channel) (W)
			I _{out} (Per Channel) (A)	Nominal V _{out} (V _{bc})	Compliance Voltage (V _{bc})		
100-120V _c Input	200-240V _{AC} Input			Typ	min	max	
XLA(L)65-115V-SWO	XLA(H)65-115V-SWO	1	3.00	15	11.0	15.8	47
XLA(L)65-118V-SWO	XLA(H)65-118V-SWO	1	3.00	18	13.2	18.9	57
XLA(L)65-124V-SWO	XLA(H)65-124V-SWO	1	2.10	24	17.6	25.2	53
XLA(L)65-130V-SWO	XLA(H)65-130V-SWO	1	1.5	30	21.0	31.5	50
XLA(L)65-136V-SWO	XLA(H)65-136V-SWO	1	1.50	36	26.5	37.8	57
XLA(L)65-142V-SWO	XLA(H)65-142V-SWO	1	1.40	42	30.9	44.1	62
XLA(L)65-148V-SWO	XLA(H)65-148V-SWO	1	1.05	48	35.3	50.4	53
XLA(L)65-160V-SWO	XLA(H)65-160V-SWO	1	1.00	60	44.1	63.0	63
XLA(L)65-172V-SWO	XLA(H)65-172V-SWO	1	0.80	72	52.9	75.6	61
XLA(L)65-185V-SWO	XLA(H)65-185V-SWO	1	0.70	85	62.5	89.3	63

* UL marking: for products manufactured in Vietnam only, effective October 2020.

Input Specification

Voltage Range	Frequency Range	Max Inrush Current	Power Factor	Max Input Current:	THD
XLA(L) Low Input: 100-120V _{AC} XLA(H) High Input: 200-240V _{AC}	47-63 Hz	XLA(L): 30A @ 120V _{AC} Input, 25 °C, cold start-up XLA(H): 60A @ 230V _{AC} Input, 25°C, cold start-up	0.9 min	0.6 A @ 115 V _{AC} Input	<20% @ Full load

Output Specification

Max Power	65 W	Auto-compliance Output Voltage Range	+5%/- 30% Max
Line Regulation	+/- 5% Max	Noise/Ripple	5% of Rated Output Voltage*
Current Regulation	+/- 5% Max	Short Circuit Protection	Hiccup-Mode, Auto-Recovery upon removal of short circuit condition.
Efficiency	80% Typ. @ Full Load, 230V _{AC}	Over Voltage Protection	135% Max
Start-up Time	3.0 sec. Typical	Over-current Protection (OCP)	Constant-current limiting
Hold-up Time	0.5mS @ full load, 100V _{AC} input	Output Current Regulation	+/-5% Max

* All noise measurements made at the output terminals, connected to a 20MHz low pass filter.

Environmental Specifications

MTBF	Cooling	Operating Temp	Storage Temp	Relative Humidity
80,000 hours (Full load @ 25°C Ambient, Based on MIL-217F)	Convection	-25°C to 60°C (Full load)	-40°C to 80°C	5% - 95%

Compliance / Safety

EMI/RFI	ISPR-22 Class B FCC part 15 Class B EN55015, EMC
Safety Agency	UL 1012, 1310 Class 2, UL 8750, UL 879, CSA C22.2 No.107.1 CE(IEC/EN61347-1, IEC/EN61347-2-13)
Weatherability	IP 65

Supported Dimming Options:

TRIAC/ ELV (Trailing/Leading Edge)/ SCR

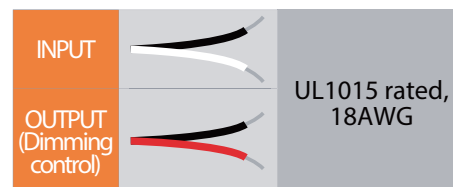

Mechanical

Material:	UV Rated Polycarbonate Plastic UL 94 V2/ Black/Dark Blue/ Potted
-----------	---

Expected Life-time*_{-SW0}

T _c	60°C	75°C
Life-time	50,000h	30,000h

*: @ Full load, based on a failure rate of < 10%

Performance Curves

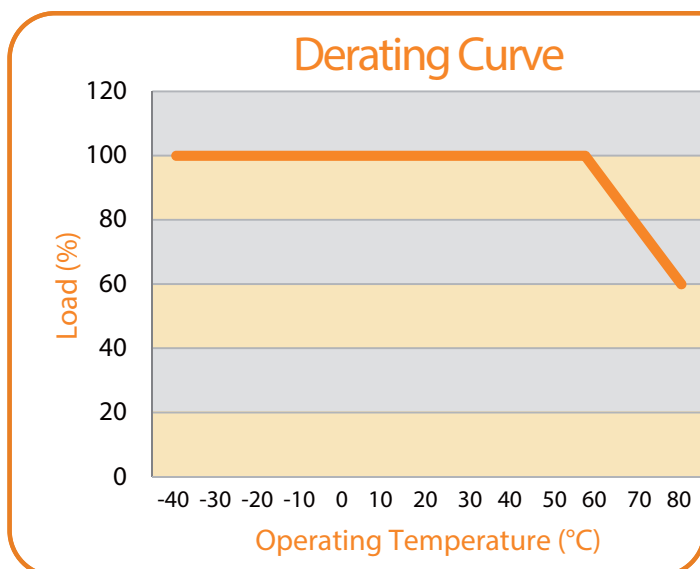
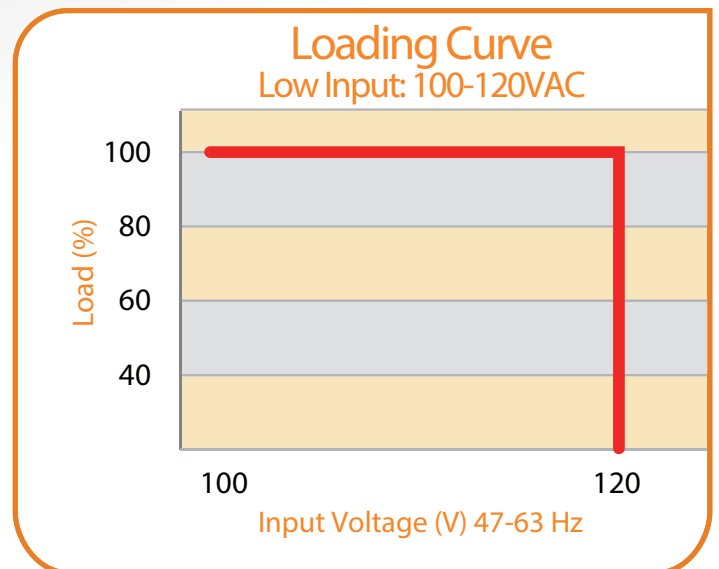
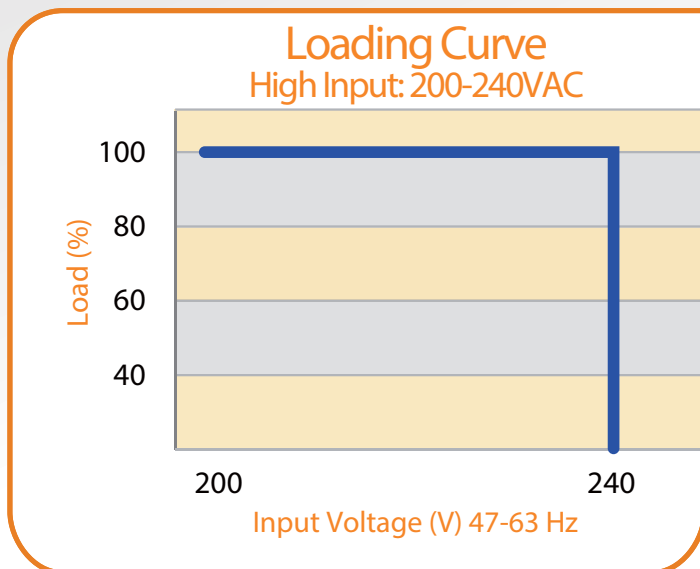
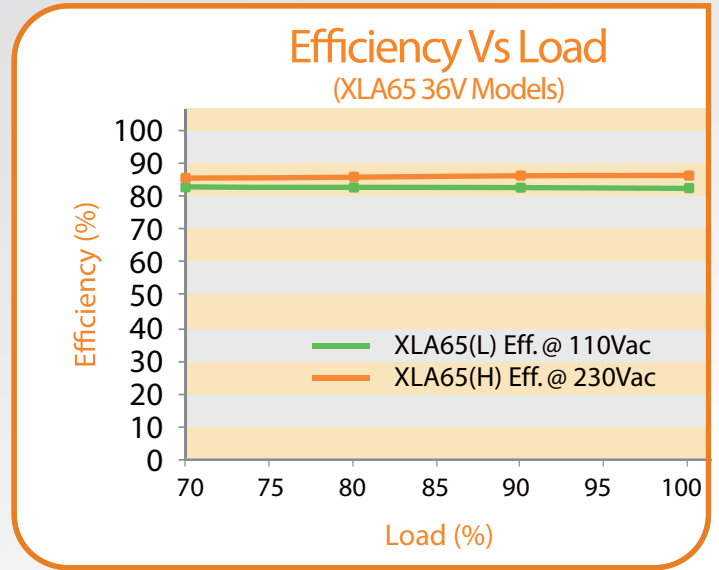
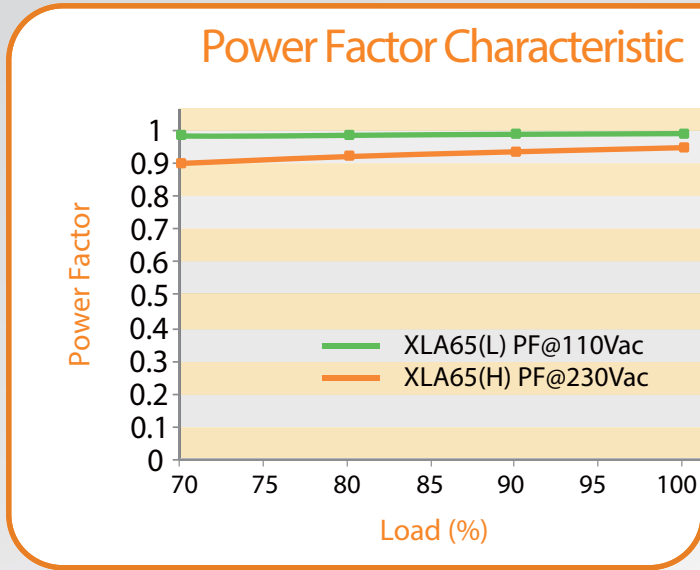

Supported Dimmer List

100~120V_{AC} ELV (Trailing Edge) & Triac (Leading Edge) Dimmer

Brand	Model	Dimmer Rating Power (max)	LED Flicker Free Test *
Cooper Wiring Devices	RI061-A (Rotary Dimmer w/ Non-Preset)	600W	Pass
Cooper Wiring Devices	6001	600W	Pass
Cooper Wiring Devices	SLC03P (C/L)	600W	Pass
Cooper Wiring Devices	SI06P (non C/L)	600W	Pass
GE	DI61-271	600W	Pass
GE	DIB61-71	600W	Pass
GE	DIT61-71	600W	Pass
GE	DIT61-S71	600W	Pass
Gira	1184	400W	Pass
Legrand	RS-100BA-W-CS (Wattstopper occupancy sensor)	500W	Pass
Leviton	6602-IW	600W	Pass
Leviton	L02-700-W	600W	Pass
Leviton	L12-6641-W	600W	Pass
Leviton	No.6641 (Toggle Dimmer)	600W	Pass
Leviton	No.6683-IW (3-Way Push On/Off Dimmer)	600W	Pass
Leviton	R12-6631-LW	600W	Pass
Lutron	DVCL-153PL (C/L)	600W	Pass
Lutron	TGCL-153P (C/L)	600W	Pass
Lutron	AB-600M-WH (Abella)	600W	Pass (##)
Lutron	D-600RH-DK (Rotary)	600W	Pass
Lutron	D-600R-WH (Rotary)	600W	Pass
Lutron	D-603PG-WH (Rotary)	600W	Pass
Lutron	GL-603PH-DK (GLYDER - 3-way)	600W	Pass
Lutron	GL-600-WH (Glyder)	600W	Pass (##)
Lutron	MA-600GH-WH (Ecodim Digital with indicator leds)	500W	Pass (##)
Lutron	MIR-600THW-WH (RC Digital Fade Dimmer)	600W	Pass
Lutron	MS-VP600GHW-WH (Vacancy Sensor w/ eco-dim Dimmer)	600W	Pass(##)
Lutron	S-600PH-WH (SKYLARK)	600W	Pass
Lutron	SELV-300PH-WH (SKYLARK - Single Pole)	300W	Pass
Lutron	TG-600PH-WH (Toggler)	600W	Pass
Lutron	TG-603PFH-WH (Toggler - eco-dim)	600W	Pass
Lutron	TT300NLH-BL	600W	Pass
Lutron	TT-300NLH-BL	300W	Pass
Lutron	D-600PH-DK (non C/L)		

Remarks:

* - Flicker tests were carried out to ensure full range, flicker-free dimming from min to full load. The XLA series offers the industry's only full-range 0-100% dimming. This is a representative list of dimmers only. GRE Alpha makes no specific recommendation on product selection and there are no warranties of performance or compatibility implied. Refer to dimmer manufacturers for further information on LED compatibility.

- Lutron, Leviton, Legrand, Cooper and their product brand names are registered trademarks of each respective company.

- 5-100% dimming range.

Supported Dimmer List

220~240V_{AC} ELV (Trailing Edge) & Triac (Leading Edge) Dimmer

Brand	Model	Dimmer Rating Power (max)	LED Flicker Free Test *
Air-Lux (Key-Top)	AL-18	600W	Pass
BG-British	BG General	400W	Pass
Brennenstuhl	RD300	300W	Pass
Busch	6513U-102	420W	Pass
Bush-Jaeger	2247U	500W	Pass
Bush-Jaeger	2250U	600W	Pass
Bush-Jaeger	6519U	550W	Pass
Clipsal	32E450UDM	450W	Pass
Clipsal	E32V500/2K	500W	Pass
Clipsal	KB31RD400	400W	Pass
Ehmann	4660	315W	Pass
Ehmann	10UP-kpl	300W	Pass
Ehmann	39 Domus	500W	Pass
Everflourish	EFO700D	300W	Pass
Gira	1184	400W	Pass
HPM	CAT700T	700W	Pass
Italy	DG04027	400W	Pass
JingNeng	JN2301	300W	Pass
KEY-TOP	DP-81	600W	Pass
Legrand	V8051	600W	Pass
LK	DG07103	400W	Pass
Meierte	PDDT	630W	Pass
MK	S1535	1000W	Pass
MK	SX8501	500W	Pass
Opus	852.39	400W	Pass
Opus	852.392	500W	Pass
ShitoneSB	DIM	300W	Pass
Super Star	BP-200	200W	Pass
T&J	P2037S	630W	Pass

Remark:

- * - Flicker tests were carried out to ensure full range, flicker-free dimming from min to full load. The XLA series offers the industry's only full-range 0-100% dimming. This is a representative list of dimmers only. GRE Alpha makes no specific recommendation on product selection and there are no warranties of performance or compatibility implied. Refer to dimmer manufactureres for further information on LED compatibility.
- The above dimmer brand names are registered trademarks of each respective company.

Mechanical and Wiring Diagrams

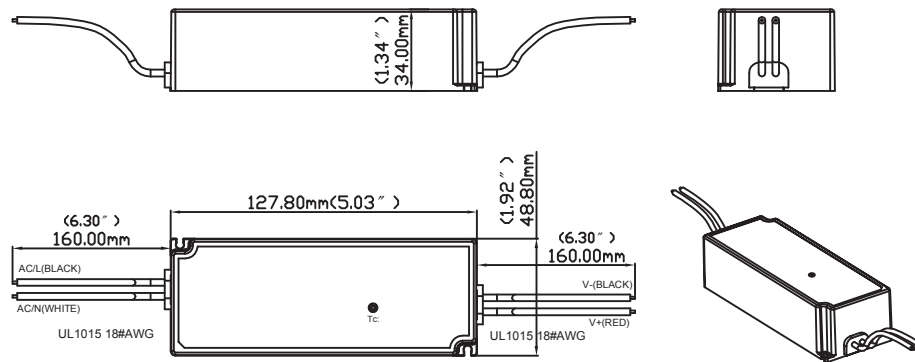

Packing Information for SWO:
 Weight: 0.320 kg/pcs, 20.4 kg/carton
 60 pcs/carton; L415xW367xH218 (mm)

Configuration Arrays

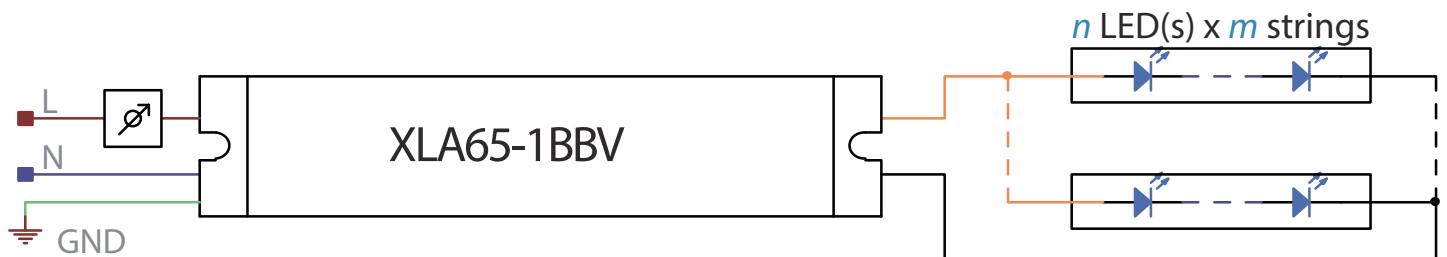

Model	Output Voltage	Compliance Voltage Range (V)	Recommended n LED(s) per String *	Current POT Adjust Range (A)
5	8	3 . 9 8 - 5	. 2 6 3 3 -	7 1 0 7 . 0
2	7	6 . 5 7 - 9	. 2 5 8 2 -	4 1 0 8 . 0
0	6	0 . 3 6 - 1	. 4 4 3 2 -	2 1 0 0 . 1
8	4	4 . 0 5 - 3	. 5 3 8 1 -	9 5 0 . 1
2	4	1 . 4 4 - 9	. 0 3 6 1 -	8 0 4 . 1
6	3	8 . 7 3 - 5	. 6 2 4 1 -	7 0 5 . 1
4	2	2 . 5 2 - 6	. 7 1 9 - 4	0 1 . 2
8	1	9 . 8 1 - 2	. 3 1 7 - 3	0 0 . 3
5	1	8 . 5 1 - 0	. 1 1 5 - 3	0 0 . 3

* LED Vf range: 2.7-3.6 V

Information furnished is believed to be accurate and reliable. However, GRE Alpha assumes no responsibility for the consequences of use of such information nor for any infringement of patents or other rights of third parties which may result from its use. No license is granted by implication or otherwise under any patent or patent rights of GRE Alpha. Specifications mentioned in this publication are subject to change without notice. This publication supersedes and replaces all information previously supplied.

The GRE Alpha logo is a registered trademark of GRE Alpha Electronics Ltd.
 All other names are the property of their respective owners